

# M 130

Double Ribbon Microphone

Order # 129.534



## FEATURES

- Double ribbon microphone
- Consistent figure-eight polar pattern
- Superb transient response
- Characteristically warm and natural sound
- Made in Germany

## APPLICATIONS

In contrast to many other ribbon microphones, this dynamic ribbon microphone has two ribbons arranged one above the other, at a distance of only 0.5 mm resulting in an unusually smooth and balanced frequency response. Together with the ideal impulse response which is typical for ribbon microphones, the M 130 is a microphone which is characterised by an exceptional freedom from discoloration and natural sound. Its figure eight polar pattern is unusual for a dynamic microphone, as it remains constant over the entire frequency range, with no sound changes whatsoever, even at lateral speech angles. In conjunction with the M 160 double ribbon microphone, the M 130 is used for MS stereophony. While it can be used for recording dialogues and for involving the audience in the transmission of a stage event, it is also recommended for miking drums to pick up two adjacent instruments or at the grand piano. Other applications as an instrument microphone are quite popular to use the warm, precise sound of a ribbon microphone for recording.

## TECHNICAL SPECIFICATIONS

Transducer type..... Dynamic  
Operating principle ..... Pressure gradient  
Frequency response ..... 40 - 18,000 Hz  
Polar pattern..... Figure-eight  
Rear attenuation at 1 kHz ..... > 30 dB at 90°  
Open circuit voltage at 1 kHz  
(0 dB = 1 V/Pa) ..... 1.3 mV/Pa = -57.5 dBV  
Nominal impedance..... 200 Ω  
Load impedance..... ≥ 1000 Ω  
Diaphragm ..... Pure aluminium  
Case/finish ..... Brass  
Connector..... XLR, 3-pin, male  
Dimensions:  
Length..... 128 mm  
Shaft diameter ..... 23 mm  
Head diameter ..... 38.5 mm  
Weight without cable..... 150 g

## SUPPLIED ACCESSORY

MA-CL 25      Microphone clamp with  
                         3/8" internal thread,  
                         with internal diameter  
                         of 25 mm ..... Order # 727.954

## OPTIONAL ACCESSORY

EA 19/25      Elastic suspension for shaft  
                         diameter of 19 - 25 mm,  
                         with MA-CL 36 microphone  
                         clamp..... Order # 407.194

# M 130

## FREQUENCY RESPONSE & POLAR PATTERN

This frequency response curve (measuring tolerance  $\pm 2.5$  dB) and polar pattern correspond to a typical production sample for this microphone.

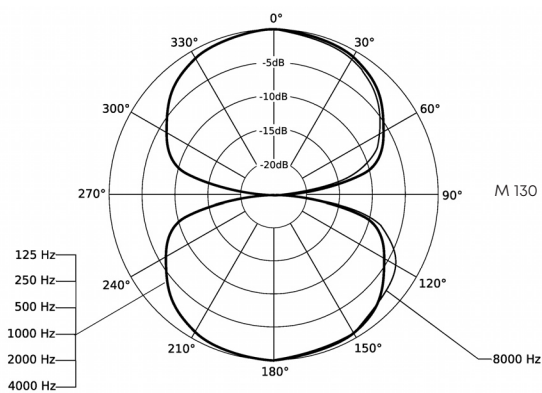
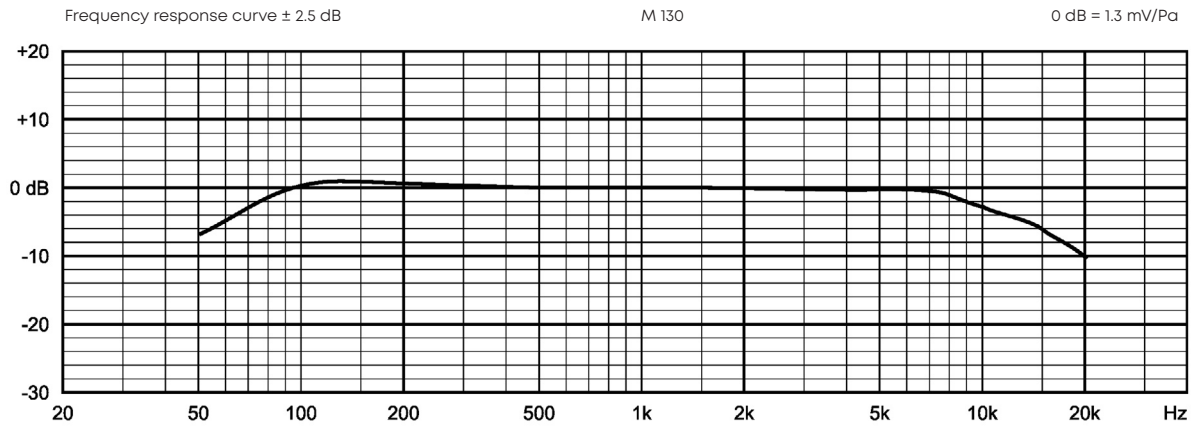

## WIRING DIAGRAM

